

ABLE

GASOLINE PILE DRIVER

Model: POSTDRV33

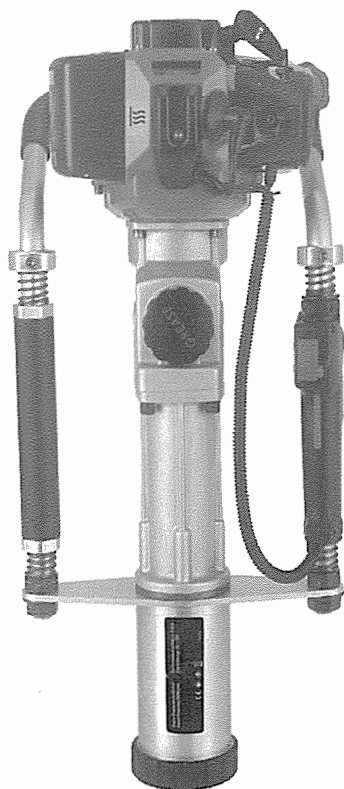

ORIGINALINSTRUCTIONS



Read the operating instructions thoroughly before work and keep it for future reference.

User Manual

For your safety, please read the manual carefully before using the machine, otherwise physical injury or mechanical damage may be caused.

Symbols



Read instruction manual and follow the warning and safety precautions!



Particular care and caution!



Wear protective helmet, eye and ear protection, and respiratory protection!



Wear protective gloves!



No smoking!



No open fire!



Fuel (Gasoline)

1. Name of Main Parts

No.	Name of Part	No.	Name of Part	No.	Name of Part
1	Combination Switch	2	Stop Button	3	Spark Plug Cap
4	Ventilation Switch	5	Oil Can	6	Handle Rack
7	Fuel Bubble	8	Throttle Knob	9	Throttle Button
10	Front Placket	11	Piling Socket	12	Piling Socket Retainer
13	Support Plate	14	Handle Sleeve	15	Grease Cap
16	Positioning Sleeve	17	Starter	18	Oil Can Top
19	Air Filter	20	Damping Spring	21	Throttle Pull

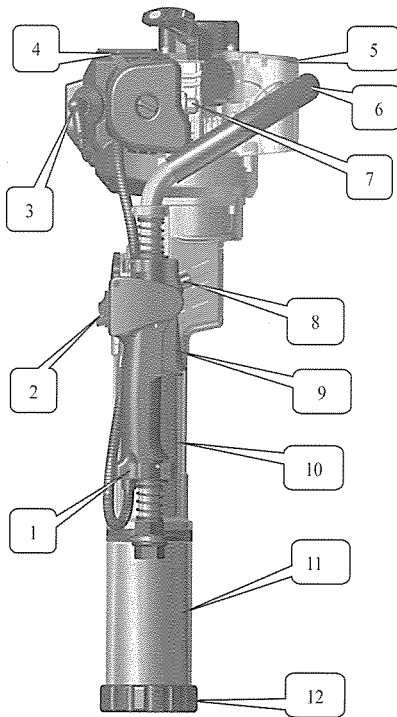

Fig 1

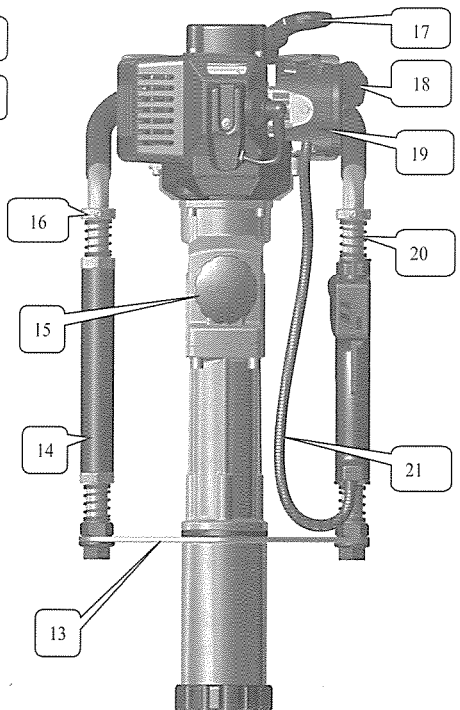

Fig 2

2 . Description of Safe Operation

1. The operator must wear slip-resistant safety shoes and suitable clothing. For long-time operation, he or she must wear a goggle, a helmet, and earplugs.
2. While operating the machine, please keep balance of the body, and stand in front of Air Filter to operate the machine. The operator shall not smoke, eat or chat while operating the machine.
3. After starting the machine, do not operate it with one hand.
4. When lifting the machine do not pulled the throttle button, which will cause the machine to run at idle.
5. Non-staff shall be away from the operation area to avoid injuries.
6. Operate the pile driver at the medium speed.
7. Keep the handle dry and clean without greasy oil or fuel mixture.
8. If operation is stopped midway; be sure to turn off the engine.
9. Be sure to check whether fastening screws of the connector is tightened before use. If it's loose, it's necessary to tighten the screws before use.
10. Prohibit the use of pure gasoline fuel (no two-stroke oil), shall refer to Chapter 4.2 for recommended ratios of fuel.
11. Gasoline is highly flammable. Therefore, replenish fuel in a well-ventilated environment. During fuel filling, gasoline engine must be turned off.
12. Do not add too much oil. The oil shall not exceed the neck of oil filer of fuel tank. If fuel spills, start the machine after fuel on the machine volatilizes completely.
13. After refueling, tighten the oil lid. During work, check whether oil can is damaged and spills frequently. If damage is found, close down the machine immediately for replacement.
14. Reserve oil in storage areas. Remove hidden troubles of fire or open flame.
15. While the pile driver is used in closed areas such as tunnels, trenches and deep groove, it's necessary to guarantee normal air circulation to avoid waste gas poisoning and suffocation.
16. Forbid quick acceleration or braking so as not to damage the machine.
17. Before transport, empty fuel inside the fuel tank to avoid leakage.
18. Non-professional maintenance staff are prohibited from dismantling the pile driver to avoid structural damage of parts, shortened service life of the pile driver or accidents.

3. Main Use and Function

3.1 Use: It can be used for outside piling operation of farms, orchard fences or barriers.

3.2 Function

- 3.2.1 It is the engine-type handheld gasoline pile driver which boasts light weight and low discharge capacity.
- 3.2.2 The product conforms to the design of man-machine engineering, reduces working strength of the operator to the greatest extent, and boasts simple and comfortable operation. The operator can achieve 360° all-around operation.
- 3.2.3 It can regulate impact energy and impact frequency and apply to a variety of piles between 20-80mm (inclusive) in diameter.
- 3.2.4 Advantage: Save the trouble of using heavy machines such as generator, air compressor and trucking-lorry.
- 3.2.5 The operating handle of the machine is rubber and plastic sponge handle which can greatly reduce the recoil force of the machine. It's installed with two-way damping spring which makes the user more comfortable.

4.Preparation before Use

4.1Piling Socket

4.1.1 Install or change piling socket retainer. Select a corresponding retainer according to the sizes of the piling from 20mm-45mm or 46mm-80mm, as it's shown in Fig.3., such as

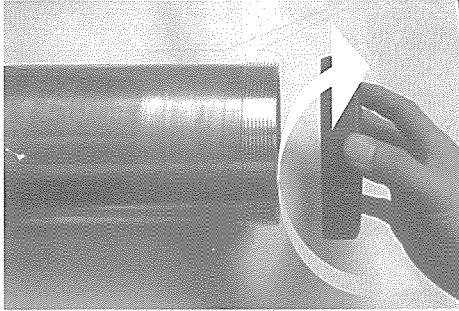

Fig 3

4.2 Fuel

Use 90# gasoline and two-stroke special engine oil or above

Recommended mixing ratio

Condition	Gasoline: engine oil
Operation within 20 hours	20:1
Operation of over 20 hours	25:1

4.2.1 Pure gasoline (without two-stroke engine oil) is forbidden as fuel.

4.2.2 Add fuel in a well-ventilated place.

4.2.3 Do not add too much oil. The oil shall not exceed the neck of oil can. If fuel spills, wait until the fuel volatilizes completely and then start the machine.

4.2.4 After refueling, tighten the lid of Oil can.

5.Starting

5.1. Before starting the new machine, press the transparent and semi-circle fuel bubble repeatedly (Fig.4) until carburetor is filled with fuel. (If the engine is cool, close the air door. Open air door after starting.)

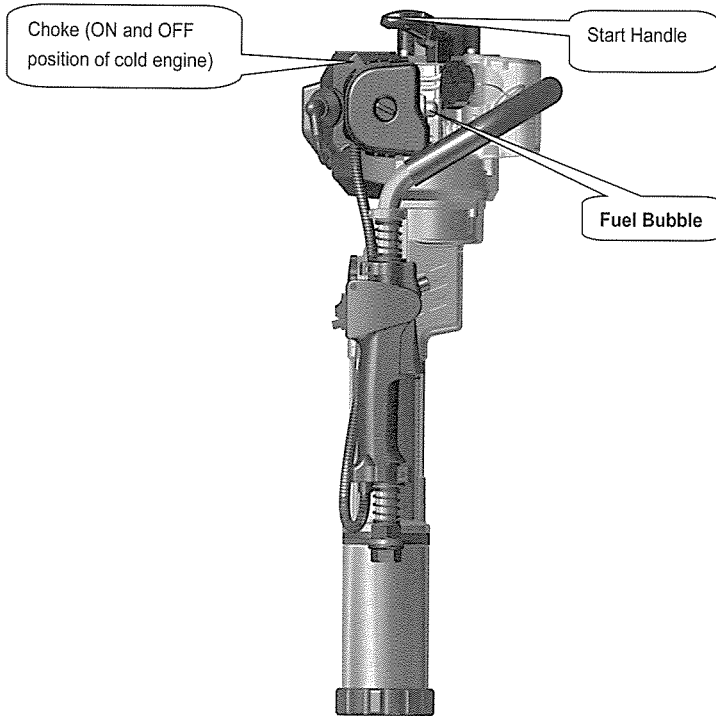

Fig 4

5.2. Set the machine upright according to Fig. 4. Hold the upper part of the handle tightly with one hand while the other pulls the pulling handle of starter for over 50cm quickly. Do not let the pulling handle go back freely in repeated pulling but hold it tightly to avoid injury resulting from quick resilience.

5.3. Start the gasoline engine and then open air door completely. After idle operation for 5 minutes, start normal work.

6. Operation

6.1 After gasoline engine is started, first carry out idle operation for 5 minutes to warm up the machine.

6.2 When the gasoline engine is warmed up, press throttle button to the appropriate regulatory position according to the required impact energy.

Note: The new gasoline pile driver use shall mainly boast low or medium-speed for work in the first 20 hours of the operation and the maximum throttle shall no be used in order to extend the service life.

6.3. Operating speed of gasoline engine shall be low or medium speed.

6.4. High-speed operation of the pile driver during non-piling is prohibited.

7. Turning off the Machine

7.1 Release throttle button and carry out idle running of the machine for 3-5 minutes.

7.2 Pull Stop Button to the position of flameout. See the position of Stop Button in Fig.5.

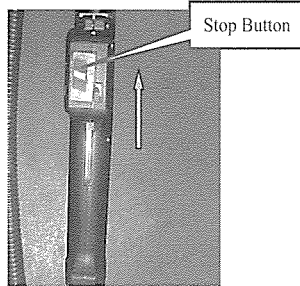

Fig 5

8. Technical Maintenance

8.1 Air Filter

Check air filter regularly. Soot deposit blocking the filter element of the air filter will reduce the power of gasoline engine and service life. If the filter has too much soot deposit, clean it with warm water and detergent, and then install the air filter after wiping it with dry cloth. Filter should be replaced if damaged. Maintenance cycle shall be shortened properly if it's particularly used in the dusty environment..

8.2 Fuel filter

If the fuel filter is blocked, the pile driver will have reduced speed and weaker impact energy. Methods:

①Open the oil can lid. Get out the fuel filter from the oil can with metal hook and clean it. ②When cleaning the fuel filter, clean the oil can at the same time as it's shown in Fig.6,7 and8.

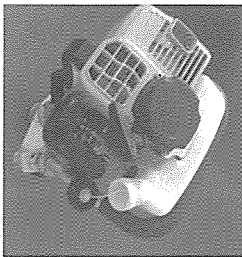

Fig 6

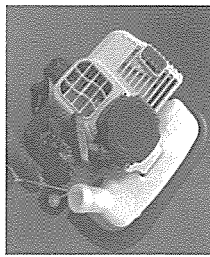

Fig 7

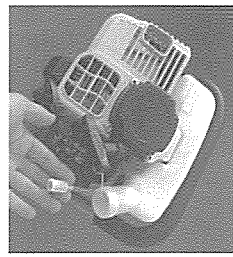

Fig 8

8.3 Carburetor

Oil can and carburetor generally have residual oil. After some time, the residual oil will become greasy oil which will block up the oil line, causing incapability of starting the engine. Therefore, when the machine is not used for more than one week, be sure to completely take the fuel out. Method: Pull out the oil inlet pipe, press the fuel bubble of the carburetor repeatedly for oil discharge, and press the oil inlet pipe back to its position when fuel in the fuel bubble and oil return pipe is emptied.

8.4 Spark Plug

To ensure normal operation of the engine, the spark plug gap must be proper. Remove sediment with a wire brush. Proper gap of the spark plug is 0.5-0.7 mm. See Fig.9

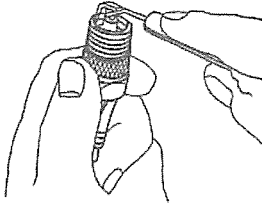

Fig 9

8.5 Silencer

Regularly remove dirt on inlet and outlet of the muffler, or clean dirt in it with detergent.

8.7 The cylinder cooling fin

Regularly remove dust to ensure timely cylinder cooling. The gasoline pile driver is air-cooler type. If dust accumulates on the cylinder heat sink, the cooling effect will be influenced directly which will cause bugs of the gasoline pile driver.

8.7 Refuel lubrication to Impact Cylinder

After the accumulated working hour reaches 50 hours, it is necessary to refuel impact cylinder with 50g specific oil. See Fig.10.

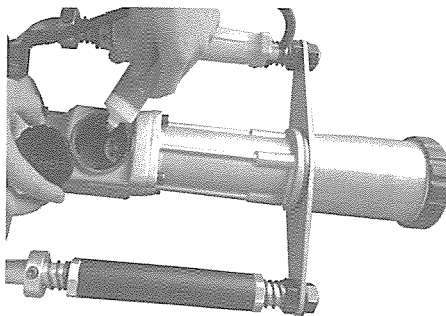
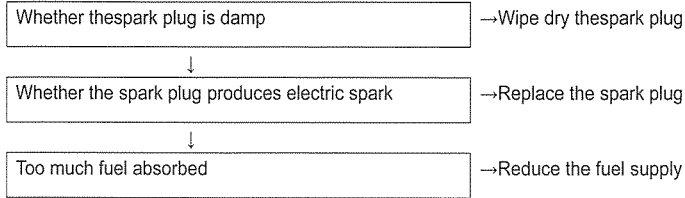

Fig 10

9. Failure Analysis and Its Eliminating Methods

Problem analysis and solving

Example 1: Difficulties in starting engine in cooling state.



Example 2: Difficulties in restarting after a sudden stop

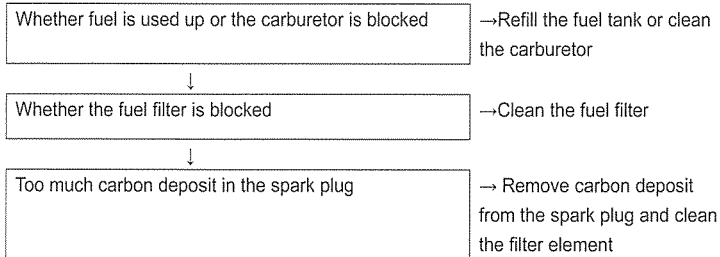

Example 3: Slow speed and weak power

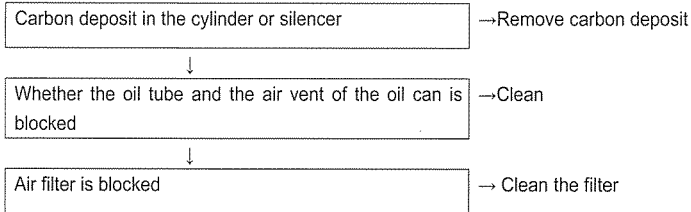

Example 4: Abnormal sound

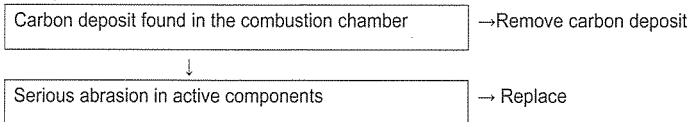

Example 5: The machine is working normally but the work efficiency is very low

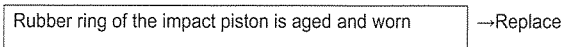

Please contact with local sales agent or contractual maintenance site for maintenance.

10.Key Data of Product

Gasoline engine type	Single cylinder, air cooling, 2 stroke
Model	POSTDRV33
Fuel	Mixed oil (Gasoline: two-stroke engine oil=25:1)
Fuel tank capacity	0.9L
Weight (excluding fitting)	11Kg
Displacement	32.7cm ³
Max torque and speed	1.45N.m/5000r/min
Fuel consumption rate	≤0.50L/h
Impact frequency	2000b/min
Impact energy	20~55J
Starter system	Hand pull start
Max engine speed	10500/min
Max power and speed	1KW/9000r/min
Idling speed	3500/min

11.Maintenance Cycle

The following Data are given from the common use of the product. Under worse working conditions such as dusty environment or long work hours of the pile driver, the maintenance cycle should be shortened correspondingly.		Before work	After work or every day	After Filling oil	Every Week	Every Month	Temporary Failure	If necessary
The whole machine	Outlook check (state, tightness of screws)	√		√				
	Clean		√					
Control handle/stop button	Function check	√		√				
Air Filter	Clean				√			√
	Replace						√	
Fuel Filter	Check					√		
	Replace						√	
Oil can/Oil can cover	Clean		√	√				
	Check	√		√				
	Tighten							√
Reduction Gear Box/Impact Cylinder	Clean					√		
	Add oil							√
Silencer	Check					√		
	Remove carbon deposit							√
Cylinder Cooling Fin	Check					√		
	Clean							√
Spark Plug	Check/Adjust the distance between electrodes					√		
	Replace							√
Screw and Nut	Check	√		√				
	Tighten							√

12. Parts List and Exploded View of POSTDRV33 Pile Driver

Parts No.	Name	Qty	Parts No.	Name	Qty
1	Gasoline Engine	1	34	Front Placket	1
2	Driven Disk	1	35	Elastic Washer 8	8
3	Inner Hexagon Cylindrical-head Screw M5×12	3	36	Inner Hexagon Cylindrical-head Screw M8×20	4
4	Elastic Washer 5	3	37	Front Paper Pad	1
5	Bearing Pressing Plate	1	38	Hammer O-circle	1
6	Deep Groove Ball Bearings 6202-2RS	3	39	Hammer	1
7	Small Bevel Gear	1	40	Crush Pad	2
8	Reduction Gearbox	1	41	Waved Gasket φ39×46×0.5	4
9	Oil Cover	1	42	Shock O-circle	2
10	O-ring Oil Cover	1	43	Shock	1
11	Inner Hexagon Cylindrical-head Screw M6×16	1	44	Impact Socket	1
12	Elastic Washer 6	5	45	Support Plate	1
13	Retainer	1	46	Hexagon Flange Nut M18×1.5	2
14	Needle Roller Bearings HK152316	1	47	Piling Socket	1
15	Impact Crankshaft	1	48	Inner Hexagon Cylindrical-head Screw M8×40	4
16	-A Type Common Flat Key 5×5×10	1	49	Inner Pile Head 77	1
17	Deep Groove Ball Bearings 6003-2RS	1	50	Piling Socket Retainer 80	1
18	6003 Bearing Pressing Plate	1	51	Piling Socket Retainer 45	1
19	Cross Pan Head Screw M5×14	4	52	Connecting Thread Head	2
20	Large Bevel Gear	1	53	Step Nut	2
21	Shaft Retainer 16	1	54	Handle Spring	4
22	Rear Paper Pad	1	55	Handle Sleeve	1
23	Round Pin 4×10	2	56	Handle Soft Sleeve	1
24	Reduction Gearbox Cover	1	57	Handle Nut	1
25	Inner Hexagon Cylindrical-head Screw M5×20	4	58	Positioning Sleeve	2
26	Inner Hexagon Cylindrical-head Screw M6×20	4	59	Inner Hexagon Cylindrical-head Screw M6×40	4
27	Cylinder Gaskets	1	60	Handle Frame (two-stroke)	1
28	Impact Connecting Rod	1	61	Handle Frame Soft Sleeve	1
29	Impact Piston	1	62	Combination Switch	1
30	Impact Piston Pin	1	63	Switch Handle Guide Sleeve	2
31	O-ring Impact Piston	1			
32	Impact Cylinder	1			
33	Middle Paper Pad	1			

13. Parts List and Exploded View of Gasoline Pile Driver

Parts No.	Name	Qty	Parts No.	Name	Qty
1-1	Cross Recessed Pan Head Combination Screw M5×20	13	1-36	Inlet Pipe	1
1-2	Starter	1	1-37	Inlet Pipe Pad	1
1-3	Starter Aluminum Pad	1	1-38	Cylinder Block	1
1-4	Start Dial Disc	1	1-39	Cylinder Block Gasket	1
1-5	Oil Seal FB12×22×7	2	1-40	Piston Ring	2
1-6	Right Crankcase	1	1-41	Piston	1
1-7	Deep Groove Ball Bearing 6201	2	1-42	Crankcase Connecting Rod Assembly	1
1-8	Woodruff Key 3×13×5	1	1-43	Needle Roller Bearing K9×12×12	1
1-9	Crankcase Pad	1	1-44	Piston Pin	1
1-10	Positioning Pin φ4×10	2	1-45	Piston Pin Retainer	2
1-11	Left Crankcase	1	1-46	Oil Tank Assembly	1
1-12	Inner Hexagon Cylindrical -head Screw M5×30 (With Spring Washer 5)	4	1-47	Oil Tank Flat Gasketφ5×φ12×φ1	2
1-13	Igniter	1	1-48	Cross Recessed Pan Head Combination Screw M5×16	2
1-14	Magnetic Flywheels	1	1-49	Oil Tank Platen Sleeve	1
1-15	Hexagon Flange Locknut M8×1.25	1	1-50	Oil Tank Platen	1
1-16	Steel Plain Washerφ8×1.5	2			
1-17	Shoe Assembly	1			
1-18	Waved Elastic Gasketφ10	2			
1-19	Clutch Bolt M8×φ10	2			
1-20	Wind Deflector	1			
1-21	Positioning Pin φ5×10	2			
1-22	Fan Cover	1			
1-23	Cross Recessed Pan Head Combination Screw M5×12	3			
1-24	Silencer Cover	1			
1-25	Hexagon Flange Bolts M5×55	2			
1-26	Silencer	1			
1-27	Silencer Pad	1			
1-28	Cylinder Block Cover Cap	1			
1-29	Cylinder Block Cover	1			
1-30	Inner Hexagon Cylindrical -head Screw M5×20 (With Spring Washer 5)	4			
1-31	Spark Plug	1			
1-32	Cross Recessed Pan Head Combination Screw M5×52	2			
1-33	Air Filter Assembly	1			
1-33-1	Thumbscrew M5×9	1			
1-33-2	Air Filter Cover	1			
1-33-3	Air Filter Seat Platen	1			
1-33-4	Filter	1			
1-33-5	Air Filter Seat Package	1			
1-34	Carbureter	1			
1-35	Carbureter Pad	1			

Exploded View of Gasoline Pile Driver

